

# SHARP

**MX-C311/MX-C310**  
Digital Full Colour Multifunctional System

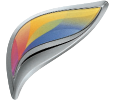

**POWERFUL PERFORMANCE FEATURES**  
IN A **UNIQUE, SPACE-SAVING DESIGN**



31 PPM IN  
B/W & COLOUR



MX-C311

LARGE TOUCH  
SCREEN COLOUR  
CONTROL PANEL

## FAST A4 COLOUR MULTIFUNCTION SYSTEMS THAT FIT ALMOST ANYWHERE

With the Sharp MX-C311/MX-C310 everyone in the workgroup can print and copy at speeds of 31 pages per minute and they won't even have to slow down for colour!

And the quality is just as impressive. Even at full speed, you'll get true 1200 x 1200 dpi resolution with accurate, vibrant colour and fine-line detail, thanks to our new, specially formulated toner and developer.

Fast, smart and small, these latest additions to the Sharp range have the intelligent features and high performance technology that's built into our award-winning A3 multifunction printers, packed into a unique space-saving design.

They look great, too! Thanks to Sharp's latest design initiative, these groundbreaking MFPs will fit right in with the most contemporary office environments.

### GREENER OFFICE TECHNOLOGY

Not only do these machines deliver the performance of larger, more expensive MFPs, but you'll find that they're kinder to the environment. Both models are Energy Star compliant, use our newly developed, environmentally-conscious supplies, and have a lead- and chromium-free design.

### ENHANCED PRODUCTIVITY FOR THE WHOLE WORKGROUP

Everything about these new MFPs has been designed to increase productivity. The MX-C311 boasts a large 8.5 inch colour LCD display with customisable 'keys' and handy thumbnail previews, while the MX-C310 features a 4.3 inch display. The superfast scanning, the powerful document filing and management functions, and the remote configuration and control facility for IT Administrators: this is a benchmark for all A4 MFPs of the future.

What's more, thanks to Sharp OSA®, you can customise the MX-C311/MX-C310 to automate specific business tasks - such as storing, distributing and managing documents, for example - for even greater efficiency. With Sharp, everyone enjoys 100% performance, 100% of the time.



MX-C311



MX-C310

**HIGH QUALITY  
PRINTING**  
1200 x 1200 dpi



**UP TO  
2100 SHEET  
PAPER CAPACITY**

## MX-C311/MX-C310 KEY FEATURES

### MINIMAL SPACE, MAXIMUM STYLE

- Boasts an extremely small footprint (535 x 438 mm) and a stylish new design that blends in perfectly with office décor
- Measures only 438 mm deep; ideal for placing on or next to a filing cabinet
- Optional Inner Finisher for sorting, stapling and offset stacking without taking up much space

### EASE OF USE

- Born from an award-winning line of Sharp A3 MFPs that are rated highly for ease of use and performance
- MX-C311 has 8.5-inch, touch-screen colour LCD providing thumbnail previews and user-specific Home screen with customisable keys and choice of screen colour
- MX-C310 has 4.3-inch colour LCD enabling easy operation of key functions
- USB port at the front of the MFP allows easy scan to USB memory and USB memory direct printing
- Supports the XPS format (standard for scanning; optional for printing)

### PRODUCTIVE PERFORMANCE

- Speedy output of max. 31 ppm in both colour and B/W
- Fast scan speed of max. 33 opm (originals per minute)
- Standard 600-sheet paper capacity, expandable to max. 2,100 sheets
- Supports Gigabit Ethernet and the latest network protocols and operating systems
- Full-colour network scanning to email, FTP server, desktop, network folder or USB memory and support for XPS, JPEG, TIFF and PDF formats
- Standard hard disk enables easy storage and retrieval of documents

### BREATHKING IMAGE QUALITY

- True 1,200 x 1,200-dpi high-quality printing without sacrificing speed
- Improved imaging system with new developer and toner faithfully reproduces fine lines and halftone colours
- Sharp Auto Colour Mode provides automated operation and high quality scanning and copying; text on halftone dot patterns comes out clearer than ever

### MULTI-LAYERED SECURITY SOLUTIONS

- Optional Data Security Kit encrypts and erases confidential data
- IP/MAC address filtering restricts unauthorised access
- SSL and IPsec enable data encryption for secure network communications
- Encrypted PDF with password protection for secure scanning
- Document Control function\* prevents unauthorised copying, scanning, faxing, and filing of confidential documents
- Supports the IEEE 802.1X standard for port-based network access control
- Function-specific user authentication

\* Requires optional Data Security Kit

### SHARP'S ONE-OF-A-KIND FEATURES

- Industry's first<sup>1</sup> Business Card Feeder<sup>2</sup> (option) is useful for making business card databases
- Sharp OSA (Open Systems Architecture) 3.0<sup>3</sup> allows integration with network applications and makes them accessible from the LCD control panel
- Remote access interface enables control panel to be displayed

<sup>1</sup> A4 colour MFP

<sup>2</sup> Available at a later date

<sup>3</sup> Requires optional MX-AMX2/AMX3



IN A **UNIQUE, SPACE-SAVING DESIGN**

MX-C311

MX-C310





**HIGH QUALITY  
PRINTING**  
1200 x 1200 dpi

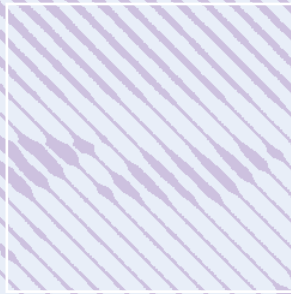

**SPACE-SAVING  
INNER FINISHER**



## PRINT IN COLOUR JUST AS FAST AS IN BLACK & WHITE

There's no need for anyone to slow down just because they want to print in colour. And even at true 1200 x 1200 dpi resolution, the reliable single-pass printing technology of the MX-C311/MX-C310 delivers the full top speeds of 31 pages per minute.

The 80 GB hard drive and powerful processor - both built-in as standard - keep performance at a maximum when handling complex graphics-rich files, and our specially formulated toner and developer deliver truly impressive quality: page after page, day after day.

### SPACE-SAVING FINISHING OPTIONS

Adding finishing options to most MFPs means sacrificing valuable office space. But not with the MX-C311/MX-C310. The optional internal document finisher adds useful sorting, stapling and offset stacking capabilities without increasing the super-small footprint of these compact machines.

### SPECIAL APPLICATIONS

For extra convenience, Form Overlay eliminates the need for pre-printed paper by storing custom document templates.

### AT A GLANCE

- Print in colour or black & white at **31 ppm**
- **True 1200 x 1200 resolution**, even at full speed.
- **Network printing** across Gigabit Ethernet and all the latest protocols and operating systems.
- **Direct printing from any standard USB memory stick**, accessed from the front of the MFP.
- **XPS/PDF/TIFF/JPEG direct print feature**<sup>\*1</sup> saves time with driverless printing of these files directly from an FTP server, Web page or e-mail attachment.
- **Supports PostScript 3<sup>2</sup>, PCL6 and PCL5c** printer language emulations with Sharp Common Graphic User Interface for ease of use.
- **Proof printing feature of the MX-C311** helps save waste by letting you check the first document before committing to a long print run.
- **Barcode font**<sup>\*3</sup> print compatibility.

\*1 MX-C310 requires optional MX-PKX5 for PDF. Both models require optional MX-PUX1 and MX-SMX3 for XPS. May not support all XPS, PDF, TIFF and JPEG file formats.

\*2 Standard for MX-C311. Optional for MX-C310 - requires MX-PKX5.

\*3 Requires optional AR-PF1

(10Base-T/100Base-TX/1000Base-T)



- Windows NT® 4.0, Windows Server™ 2003/2008
- Windows® 98/Me, Windows® 2000/XP/Vista
- Macintosh, Novell, UNIX, AS400



**AUTO COLOUR  
MODE**



**31 CPM IN  
B/W & COLOUR**

## EASY, CONVENIENT **COPYING**

Copying is not just easier with the new MX-C311/MX-C310 it's faster, too. The first copy appears in just 8 seconds (8.9 seconds for full colour), then you get the full benefit of 31 copies per minute regardless of whether you're working in colour or black & white.

The quality is just what you'd expect from Sharp, with accurate reproductions of very fine lines and accurate half-tone colours. They're so easy to use, too. Even the most advanced copy functions (of which there are many) are intuitively accessed from the control panel. And if you're scanning a mixed set of colour and black & white originals with images, text or a mixture of both, Sharp's Enhanced Auto Colour Mode will automatically adjust to give you the best possible copies.

### SPECIAL APPLICATIONS

- The colour stamp function automatically adds page numbers, the date or text such as 'CONFIDENTIAL' to every copy in up to four different colours.
- The MX-C311 has a proof copy function, which lets you check the first set of copies, and make adjustments if you need to, before committing to the full job.

### AT A GLANCE

- **Easy, efficient** colour and black and white copying at speeds of 31 copies per minute
- **Quick first copy out time** - 8.9 seconds in colour, 8.0 sec. in black and white.
- **Convenient 50-sheet Reversing Single Pass Feeder (RSPF)** makes any scan job easy; even double-sided documents are handled automatically.
- **Easy to use control panel** with 8.5-inch, touch screen colour WVGA LCD for MX-C311 and 4.3-inch colour LCD for MX-C310
- **Enhanced Auto Colour Mode** clearly reproduces text even with colour or halftone dots in the background.
- **Electronic sorting and offset stacking** for greater efficiency.
- **Auto Colour Selection** - the MX-C311/MX-C310 will automatically detect colour and black and white documents from multi-page originals and output the copy to match the original.
- **Generous paper capacity** of 600 sheets, expandable to 2,100 sheets.
- **Job Build function** - large-volume jobs can be scanned in batches and stored for output as a single job
- **Image editing functions** - multi-shot (2-in-1), card shot, pamphlet copy, image repeat, mirror image and more

### AUTO COLOUR SELECTION IN COPYING



Original with colour and black & white pages



### Colour      Black & White



Distinguishes colour and black & white pages



Outputs colour pages in Colour Mode and black & white pages in Black & White Mode

IN A **UNIQUE, SPACE-SAVING DESIGN**

MX-C311

MX-C310





**BUSINESS CARD  
SCANNING  
OPTION**

**SCAN TO EMAIL,  
NETWORK, PC,  
FTP OR USB**



## CLASS-LEADING COLOUR NETWORK SCANNING

Capable of handling up to 33 originals per minute, the MX-C311 and MX-C310 have very fast scan speeds. Now you can work with documents in batches of up to 50 at a time - in colour, black & white, or a mixture of both - as easily as you'd scan a single page.

You can scan directly into your choice of file formats, including XPS, JPEG, TIFF, PDF and encrypted PDF, and distribute them to your desktop, a network folder, FTP server or a standard USB memory stick. You can also send your scans to email recipients by making a selection from the built-in address book which, thanks to support for LDAP Lightweight Directory Access Protocol, is always kept up to date.

The MX-C311/MX-C310 can also be equipped with one of Sharp's newest scanning features: the industry's first Business Card Feeder<sup>\*1</sup>. This handy add on makes it easy to scan business cards directly to any standard business card database, using commercially available business card scan software.

### AT A GLANCE

- **Full colour scanning** to a wide choice of destinations.
- **Convenient scan and store functionality** - just plug a memory stick into the USB port at the front of the MFP and start scanning.
- **Fast scan speeds** of up to 33 originals per minute.
- **Automatically handles** colour and/or black and white documents within the same batch and adjusts output accordingly.
- **Compatible with Network TWAIN-compliant applications** (pull scan).
- **Includes Sharpdesk™** document management software.
- **Lightweight Directory Access Protocol (LDAP)** allows easy browsing of e-mail addresses for rapid distribution of scanned documents, as well as automatic synchronisation with your primary e-mail server.
- **Supports major file formats** such as XPS, JPEG, TIFF, PDF and encrypted PDF.
- **Optional business card scanning<sup>\*1</sup>.**

<sup>\*1</sup> Requires optional MX-BTX1. Available at a later date.



Convenient storage of Business Card Feeder

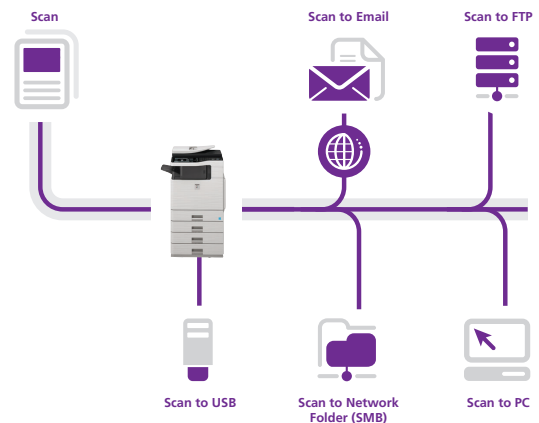

**33,600 BPS  
SUPER G3 FAX**



**FAX  
PREVIEW**

## RAPID, EFFICIENT FAXING

The optional integrated fax expansion kit makes sending faxes quick and easy for everyone in the office, without wasting space on a dedicated machine. Simply scan your documents and send them over an ultra-fast 33,600 bps Super G3 connection.

Alternatively, you can fax electronic documents directly from your PC without the need to print and scan them first.

Dealing with inbound faxes is more efficient, too. The routing function lets you direct them to the recipient's inbox without the need to create a hard copy of them and the preview function helps you decide whether you want to print them or not.

G3 14.4 Kbps



Preparation time    Transmission time    Finishing time

Super G3 36.6 Kbps



**SUPER  
G3**

### AT A GLANCE

- **Send or receive single or double-sided faxes** without the need for a dedicated fax machine.
- **Rapid transmission** with Super G3 for extra speed, plus a 50-sheet Reversing Single Pass Feeder (RSPF) for greater efficiency.
- **Paperless faxing** with inbound routing lets you check and distribute incoming faxes via e-mail.
- **Fax thumbnails<sup>1</sup> and preview function** helps you decide what to print.
- **Flash memory** prevents data loss in the event of a power failure.
- **Internet fax<sup>2</sup>** capability for sending and receiving faxes over the Internet at a fraction of the cost.
- **PC-Fax/PC-Internet Fax function<sup>3</sup>** for sending data directly from a PC to a fax machine without printing to paper.

<sup>1</sup> MX-C311 only

<sup>2</sup> Requires optional MX-FWX1

<sup>3</sup> Available for Windows only

Note: Faxing and Internet faxing are available in black and white only.

IN A **UNIQUE, SPACE-SAVING DESIGN**

MX-C311



MX-C310





**EASY ACCESS**

**MX-C311**  
**THUMBNAIL VIEW**



## EFFICIENT **FILING** FOR **FASTER** WORKFLOWS

Document management can now be more efficient than ever, thanks to an internal hard disk for storing documents and previous jobs<sup>\*1</sup>. Documents can be retrieved in moments and entire print runs can be repeated without recreating the job. Features include:



### QUICK FILING WITH TEMPORARY STORAGE (MX-C311 only)

Up to 1,000 files or 1,700 pages<sup>\*2</sup> that have been copied, printed, scanned or faxed<sup>\*3</sup> can be stored on the hard disk for future use without having to reload or rescan the original.

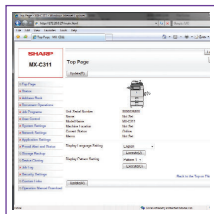

### ADVANCED FILING FOR LONG-TERM STORAGE

Save up to 3,000 files or 5,500 pages<sup>\*2</sup> in as many as 1,000 folders with customised names and locations<sup>\*4</sup>, and protect them from unauthorised access with Sharp's advanced security features. Storage options include:

- **Main Folder** - for storing files in a central location for convenient workgroup sharing
- **Custom Folder** - (MX-C311 only) - for storing confidential data in password-protected private folders

### Easy access

Documents that are stored<sup>\*1</sup> on the MX-C311/MX-C310's hard disk can be accessed either directly from the MFP's control panel or from across the network via a web page.

### Thumbnail viewing (MX-C311 only)

Convenient thumbnails of stored files make it quicker and easier to identify stored documents

### Secure storage

With the optional Data Security Kit installed, all of the data that goes through the MX-C311/MX-C310 hard disk is automatically encrypted, giving you total protection from unauthorised access.

<sup>\*1</sup> MX-C310 stores print jobs only

<sup>\*2</sup> Measured using Sharp's standard chart (A4 with 6% coverage, black and white). The Quick File Folder shares the HDD with the Job Build function; up to 12GB of data storage is available when using both functions. The storage capacity is less for colour pages.

<sup>\*3</sup> For fax and internet fax jobs, only transmitted data (not received faxes) can be saved in the Document Filing function.

<sup>\*4</sup> Storage in Custom Folders available for MX-C311 only





SHARP OSA®



EASY  
MANAGEMENT

## POWERFUL UTILITY SOFTWARE

### EASY DOCUMENT MANAGEMENT WITH SHARPCOMPOSE™

Sharpcompose document management software gives you and your colleagues a powerful, desktop-based, document management system that's capable of handling more than 200 different file formats.

It lets you browse, sort, search and share files with anyone on the network, as well as giving you the ability to create new documents that combine scanned data with files created in popular office applications such as Microsoft® Word. Features include:

- Intuitive desktop display with **thumbnail viewing**
- Sharpcompose Imaging provides **annotation tools** for paper-free proofreading
- Sharpcompose **Composer** combines different types of files into a single document
- **Optical character recognition** converts documents into editable text files
- **Output zone** distributes files to e-mail, printers and other applications
- **File search** allows searching by file name, keyword or thumbnail

### Sharp OSA® (Open Systems Architecture)

You can enhance the productivity still further thanks to Sharp OSA, which lets 3rd party developers directly integrate the MFP with your business applications. No other A4 MFP offers this level of functionality. Sharp OSA modules include:

- **Application Integration Module (MX-AMX1)** - lets users add data to scanned documents before sending them directly to applications for processing and archiving.
- **Application Communication Module (MX-AMX2)** - lets remote applications create, configure, and execute scanning and printing jobs on the MFP.
- **External Account Module (MX-AMX3)** - tracks usage by individuals and workgroups and restricts usage according to individual access rights.

### ADVANCED DEVICE AND JOB MANAGEMENT

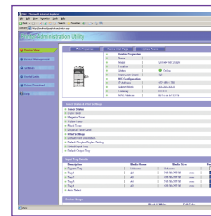

Web Based PAU

- Sharp's acclaimed Printer Administration Utility makes printer networks easier to manage by allowing network administrators to customise monitored items and view settings, such as the IP address, directly from their PC through a standard Web browser.

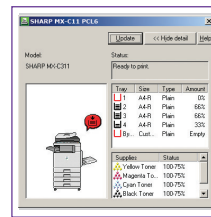

Printer Status Monitor

- Before even starting a job and without leaving your desk, the Printer Status Monitor lets you check the status of the MX-C311/MX-C310 - to see if it has sufficient paper and toner, for instance - through a simple, icon-based graphical interface on your PC desktop. It also lets you know when your job has been completed and is ready for collection.

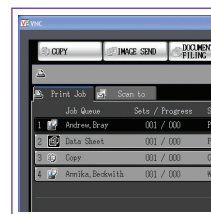

Job Status Screen

- Whether printing or copying, the Job Status Screen on the control panel displays a list of all jobs to give you an at-a-glance view of the jobs in progress and the position of your job in the queue.

IN A UNIQUE, SPACE-SAVING DESIGN

MX-C311

MX-C310



DOCUMENT  
CONTROL



DATA  
SECURITY

## INDUSTRY-LEADING MULTI-LAYER SECURITY

The MX-C311/MX-C310 safeguards sensitive data with powerful encryption technology and advanced security functions that provide multiple levels of network and data security.

### Document Control Function

Document Control<sup>1</sup> prevents the unauthorised copying, scanning, faxing and filing of confidential documents by adding copy-prevention data to a document when it is first copied or printed. If someone subsequently tries to make a copy of the document, the MX-C311/MX-C310 detects this data and cancels the job or outputs a blank page<sup>2</sup>.

### Data Security Kit

Digital copiers, printers and MFPs can retain hundreds of pages of confidential information from previous jobs on their hard disks or internal memory. To safeguard this information from unauthorised access, the optional Data Security Kit automatically encrypts the data or securely erases it on completion of the job. It also encrypts the address book.

### AT A GLANCE

- **Data Security Kit<sup>1</sup>** encrypts data on the hard disk and internal memory, removing it safely and completely after use.
- **Document Control<sup>1</sup>** prevents unauthorised copying, scanning, faxing and filing.
- **Encrypted PDF** with password protection prevents unauthorised viewing of confidential image data.
- **Secure Network Card** provides network port and protocol management, as well as a firewall that prevents direct connection and access by unauthorised users.
- **Confidential data storage** and printing protects sensitive information by requiring the user to enter a PIN code before the documents are produced.
- **Supports Secure Sockets Layer (SSL) and IPsec** for encrypted, authenticated data communication.
- **Supports IEEE 802.1X** standard for port-based network access control, which blocks access from unauthorised devices.
- **User authentication** requires logging into the machine with passwords for machine access.
- **Secure data storage for Document Filing<sup>1</sup>** - all data that goes through the hard disk is encrypted, while passwords used in the Advanced Filing function ensure solid security<sup>\*3</sup>.

<sup>\*1</sup> Requires optional Data Security Kit. Document Control Function may not work for certain types of documents and paper.

<sup>\*2</sup> May result in the output of a blank page if paper has already been fed for the job before the MX-C311/MX-C310 detects the copy prevention data.

<sup>\*3</sup> Password protection is available as standard on MX-C311 only. Encryption is optional for both models.

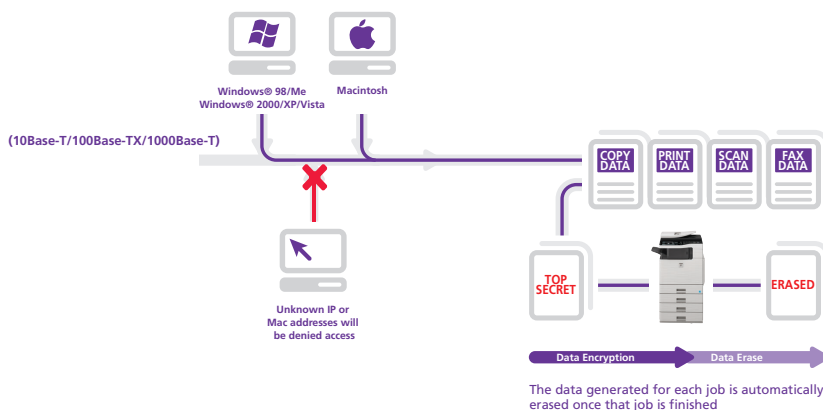

## FINISHING OPTIONS



## CONNECTIVITY OPTIONS



# MX-C311/MX-C310 OPTIONS

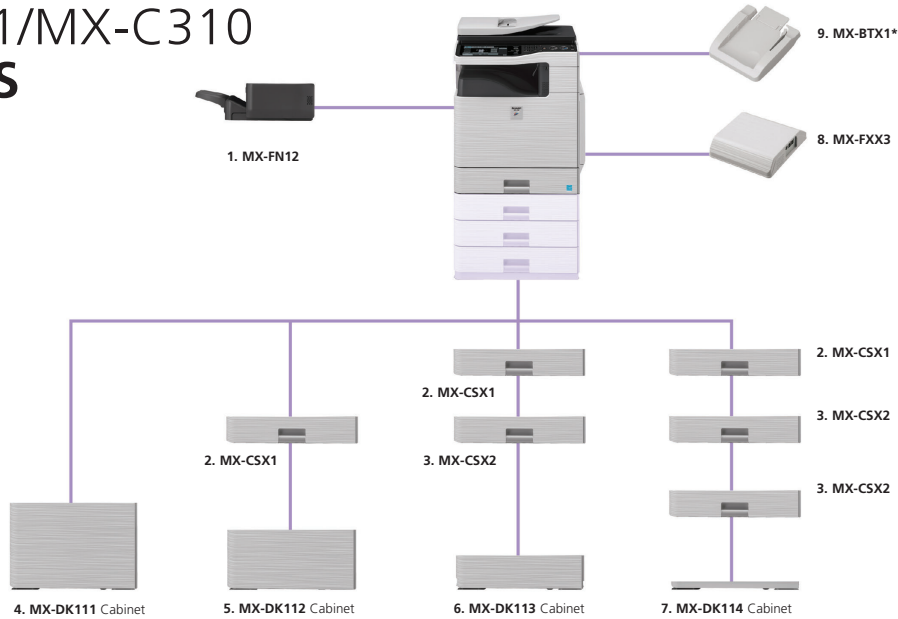

### FINISHING

#### 1. MX-FN12

A4 to A5, offset  
Paper capacity: 280 sheets (A4, 80g/m<sup>2</sup>)  
Stapling capacity: max. 30 sheets  
Staple position: 1 location (corner)

### BASE UNIT

2. **MX-CSX1 Paper Drawer**  
A4 to A5, 500 sheets (80g/m<sup>2</sup>)
3. **MX-CSX2 Paper Drawer**  
A4 to B5, 500 sheets (80g/m<sup>2</sup>)
4. **MX-DK111 Cabinet**  
Cabinet for one paper drawer
5. **MX-DK112 Cabinet**  
Cabinet for two paper drawers
6. **MX-DK113 Cabinet**  
Cabinet for three paper drawers
7. **MX-DK114 Cabinet**  
Cabinet for four paper drawers

### CONNECTIVITY BOARD

- PRINTING**  
**MX-PKX5 P5 3 Expansion Kit for MX-C310**  
 Enables PostScript printing  
**MX-PUX1 XPS Expansion Kit**  
 (MX-SMX3 required)  
**MX-SMX3 Expanded Memory Board (1GB)**  
**AR-PF1 Barcode Font Kit**
- FAXING**  
**8. MX-FXX3 Fax Expansion Kit**  
 Super G3 fax module  
**MX-FWX1 Internet Fax Expansion Kit**

### SCANNING

9. **MX-BTX1 Business Card Feeder\***

### SHARPDESK™ LICENSES

MX-USX1 x 1 user  
 MX-USX5 x 5 users  
 MX-US10 x 10 users  
 MX-US50 x 50 users  
 MX-USA0 x 100 users

### SECURITY

MX-C310  
 MX-FR12U Data Security Kit Commercial Version  
 MX-FR12 Data Security Kit Common Criteria Certified\*  
 MX-C311  
 MX-FR13U Data Security Kit Commercial Version  
 MX-FR13 Data Security Kit Common Criteria Certified\*

### SHARP OSA®

MX-AMX1 Application Integration Module  
 MX-AMX2 Application Communication Module  
 MX-AMX3 External Account Module

\* Available at a later date

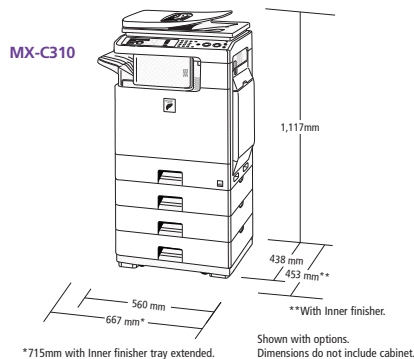
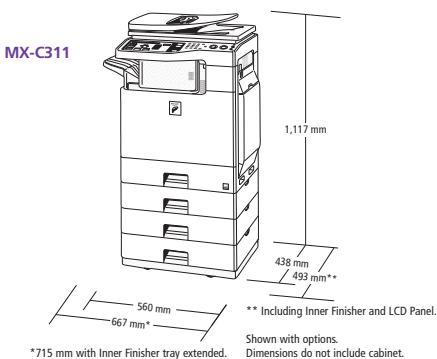

Some options may not be available in some areas.

IN A UNIQUE, SPACE-SAVING DESIGN

MX-C311

MX-C310



# SPECIFICATIONS

## MX-C311/MX-C310

Digital Full Colour Multifunctional System



General		
<b>Engine speed (max)</b>	<b>Colour</b>	<b>Black &amp; White</b>
	31 ppm/cpm	31 ppm/cpm
<b>Paper size</b>	Max. A4, min. A5	
<b>Paper weight</b>	Drawer: 60g/m <sup>2</sup> - 105g/m <sup>2</sup> Bypass: 55g/m <sup>2</sup> - 209g/m <sup>2</sup>	
<b>Paper capacity</b>	Standard: 600 sheets (500-sheet drawer and 100-sheet multi-bypass tray) Maximum: 2,100 sheets (4 x 500-sheet drawers and 100-sheet multi-bypass tray)	
<b>Warm-up time**</b>	Less than 90 sec.	
<b>Memory</b>	Copier: Standard 512MB Printer: Standard 512MB, Max. 1.5 GB 80GB HDD**2	
<b>Power requirements</b>	Rated local AC voltage ±10%, 50/60 Hz	
<b>Power consumption (max.)</b>	1.84 kW (220 to 240V)	
<b>Dimensions (W x D x H)</b>		
MX-C311	560 x 493 x 714 mm	
MX-C310	560 x 438 x 714 mm	
<b>Weight</b>	Approx. 46 kg	

Copier	
<b>Original paper size</b>	Max. A4
<b>First copy time**3</b>	Full colour: 8.9 sec., B/W: 8.0 sec.
<b>Continuous copy</b>	Max. 999 copies
<b>Resolution</b>	600 x 600 dpi
<b>Gradation</b>	Equivalent to 256 levels
<b>Zoom range</b>	50 to 200% in 1% increments
<b>Preset copy ratios</b>	8 ratios (4R/4E)

Network Scanner	
<b>Scan method</b>	Push scan (via control panel), pull scan
<b>Resolution</b>	Push scan: 100, 200, 300, 400, 600 dpi Pull scan: 75, 100, 150, 200, 300, 400, 600 dpi 50 to 9600 dpi
<b>File formats</b>	TIFF, PDF, encrypted PDF, JPEG (colour only), XPS**4
<b>Scanner utilities</b>	Sharpdesk™
<b>Scan destinations</b>	Scan to e-mail, desktop, FTP server, network folder, USB memory

Document Filing	
<b>Document filing capacity</b>	
MX-C311	Main and custom folders**5: 38GB, 5,500 pages**5 or 3,000 files Quick file folder: 12GB, 1,700 pages**5 or 1,000 files
MX-C310	Main folder**5: 38GB, 5,500 pages**5 or 3,000 files
<b>Stored jobs</b>	
MX-C311	Copy, print, scan, fax transmission**6
MX-C310	Print
<b>Storage folders</b>	
MX-C311	Quick file folder, Main folder, Custom folder (max. 1,000 folders)
MX-C310	Main folder
<b>Confidential storage</b>	
Password protection	

Network Printer	
<b>Resolution</b>	1,200 x 1,200 dpi
<b>Interface</b>	USB 2.0 10Base-T/100Base-TX/1000Base-T
<b>Supported OS</b>	Windows NT® 4.0 SP5 or later, Windows Server® 2003/2008, Windows® 98/Me/2000/XP, Windows Vista® Mac OS 9.0 to 9.2.2, Mac OS X 10.2.8, 10.3.9, 10.4 to 10.4.11, 10.5 to 10.5.1 Optional MX-PKX5 required for Mac OS for MX-C310
<b>Network protocols</b>	TCP/IP (IPv4, IPv6), IPX/SPX (NetWare), NetBEUI, EtherTalk (AppleTalk) Optional MX-PKX5 required for EtherTalk for MX-C310
<b>Printing protocols</b>	LPR, Raw TCP (port 9100), POP3 (e-mail printing), HTTP, Novell Printserver application with NDS and Bindery, FTP for downloading print files, EtherTalk printing, IPP
<b>PDL emulation</b>	
MX-C311	Standard: PCL6/5c emulation, PS3 emulation Option: XPS**7
MX-C310	Standard: PCL6/5c emulation Option: PS3 emulation**8, XPS**7
<b>Available fonts</b>	80 fonts for PCL, 136 fonts for PS3 emulation

B/W Facsimile (optional MX-FXX3 required)	
<b>Compression method</b>	MH/MR/MMR/JBIG
<b>Communication protocol</b>	Super G3/G3
<b>Transmission time</b>	Less than 3 seconds**9
<b>Modem speed</b>	33,600 bps to 2,400 bps with automatic fallback
<b>Transmission resolution</b>	Standard: 203.2 x 97.8 dpi Super Fine: 406.4 x 391 dpi
<b>Recording width</b>	A4 to A5
<b>Memory</b>	8MB flash memory
<b>Grey scale levels</b>	Equivalent to 256 levels



\*\*1 At rated voltage, 23°C \*\*2 HDD capacity depends on procurement and sourcing status. \*\*3 When feeding A4 sheets from 1st paper paper drawer, using document glass. \*\*4 To view XPS files on PCs not running Windows Vista, you must have the XPS Viewer application installed. \*\*5 Measured using Sharp's standard chart (A4 with 6% coverage, B/W). The Quick File Folder shares the HDD with the Job Build function; up to 12GB of data storage is available when using both functions. The storage capacity will be less for colour pages. \*\*6 Optional MX-FXX3 required. \*\*7 Optional MX-PUX1 and MX-SMX3 required \*\*8 Optional MX-PKX5 required. \*\*9 Based on Sharp's standard chart with approx. 700 characters at standard resolution in Super G3 mode, 33,600 bps, JBIG compression.



Design and specifications are subject to change without prior notice. All information was correct at time of print. The ENERGY STAR logo is a certification mark and may only be used to certify specific products that have been determined to meet the ENERGY STAR programme requirements. ENERGY STAR is a US registered mark. Windows and Windows NT are registered trademarks of Microsoft Corporation. SAP and all SAP logos are registered trademarks of SAP AG in Germany and in several other countries. Citrix is a trademark of Citrix Systems, Inc. and/or one or more of its subsidiaries, and may be registered in the United States Patent and Trademark Office and in other countries. All other company names, product names and logotypes are trademarks or registered trademarks of their respective owners. ©Sharp Corporation 2008 Ref: BR\_MX-C311/C310 All rights reserved. All trademarks acknowledged. E&OE.